



HAUTE COUTURE  
CARBON

BY SEBASTIAAN VANDEPUTTE

ARTELIER C  
HAUTE COUTURE LIGHT ORNAMENTS

# ARTELIER C

HAUTE COUTURE LIGHT ORNAMENTS

## In the beginning there was Artelier C. And then came the Big Bang.

ARTELIER C, an initiative of Belgian lighting specialist Claeys Verlichting, is a unique concept globally, offering a platform for talented artists seeking to turn their hand to decorative lighting.

Artelier C is not primarily for designers who produce graphic designs and concepts, but for born artists who put their heart and soul into creating unique, hand-made lighting fixtures in all possible shapes, sizes and materials.

Artelier C provides the ideal environment for these creatives, giving them the freedom to focus on their craft. The platform offers access to information, logistics support and project management assistance, as well as a worldwide administrative, financial and sales structure.

With his intergalactic universe, Belgian artist SEBASTIAAN VANDEPUTTE is the Big Bang pioneer of the Artelier C platform.

Artelier C is for enlightened artists who like to push boundaries. It's the Big Bang in the *beau monde* of architecture and design. And it's also for royalty, according to CEO Tom Claeys, who has more than thirty years' experience in exclusive lighting.

Welcome!

ARTELIER C

Tom Claeys

Doorniksesteenweg 237 - 8580 Avelgem - Belgium

T +32 56 64 48 40 - M +32 495 30 48 40 - info@arteliere.com - www.arteliere.com



# A BIG BANG

*'The chemical element carbon was at the origin of our planetary system.  
Just as carbon fibre now lies at the heart of our work at the interface  
between light and art.'*

*Sebastian Vandeputte*



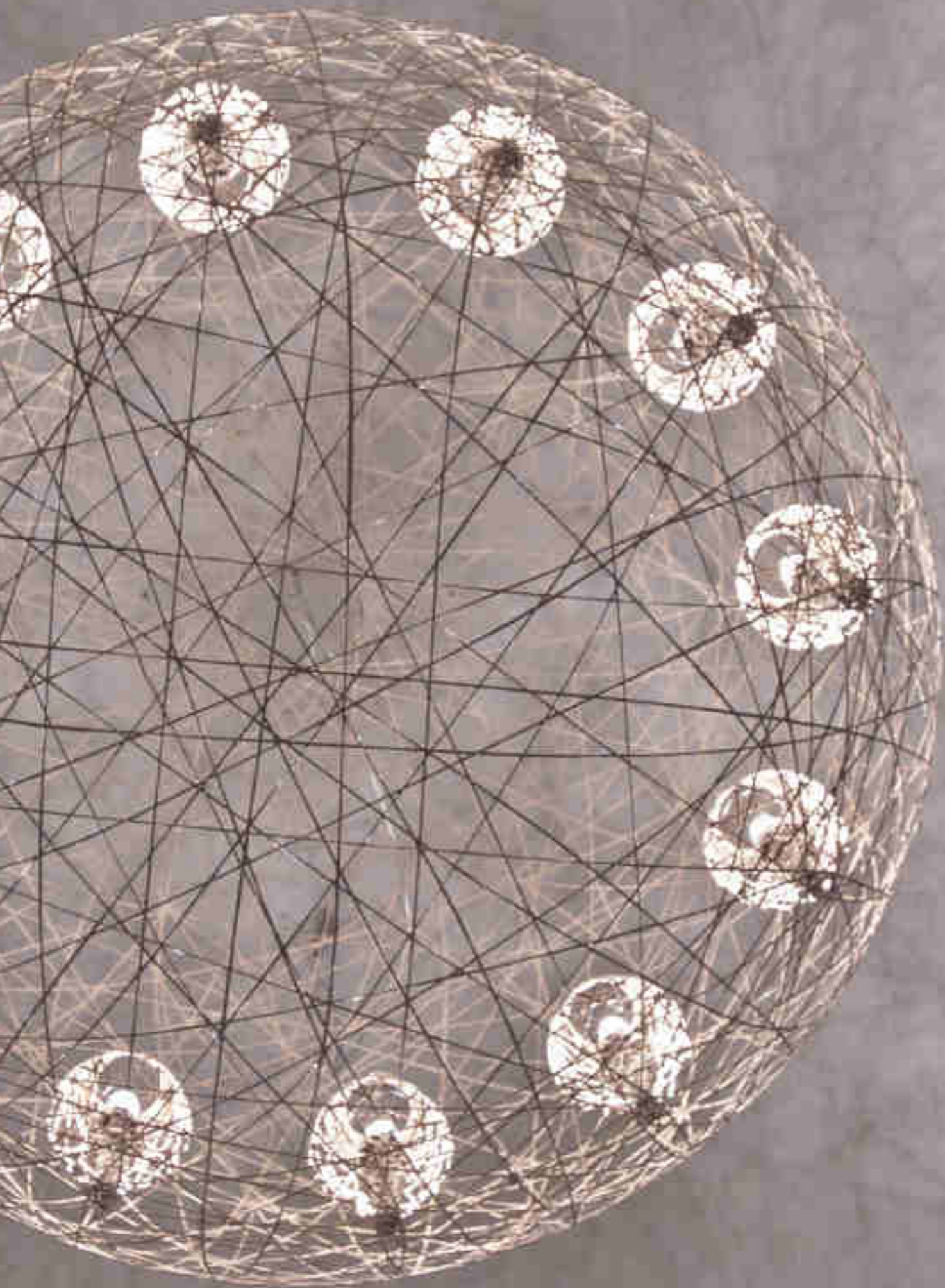

## A Big Bang

*'The chemical element carbon was at the origin of our planetary system. Just as carbon fibre now lies at the heart of our work at the interface between light and art.'*

*Sebastiaan Vandeputte*

In the international world of lighting, Artelier C is a platform for an artist who weaves pure magic using carbon fibre as his 'wand'.

We focus on royalty, says Tom.  
On the *beau monde* of architecture and design. On you.

Tom has been creating chic, exclusive lighting for the past 30 years. For him, Sebastiaan Vandeputte – Seba – is an artist who really pushes boundaries.

Seba devised a technique for working carbon fibre manually. And went on to create *Apus, Cetus, Indus, Vela...* the haute couture of lighting. Because it was written in the stars.

**A Big Bang.**



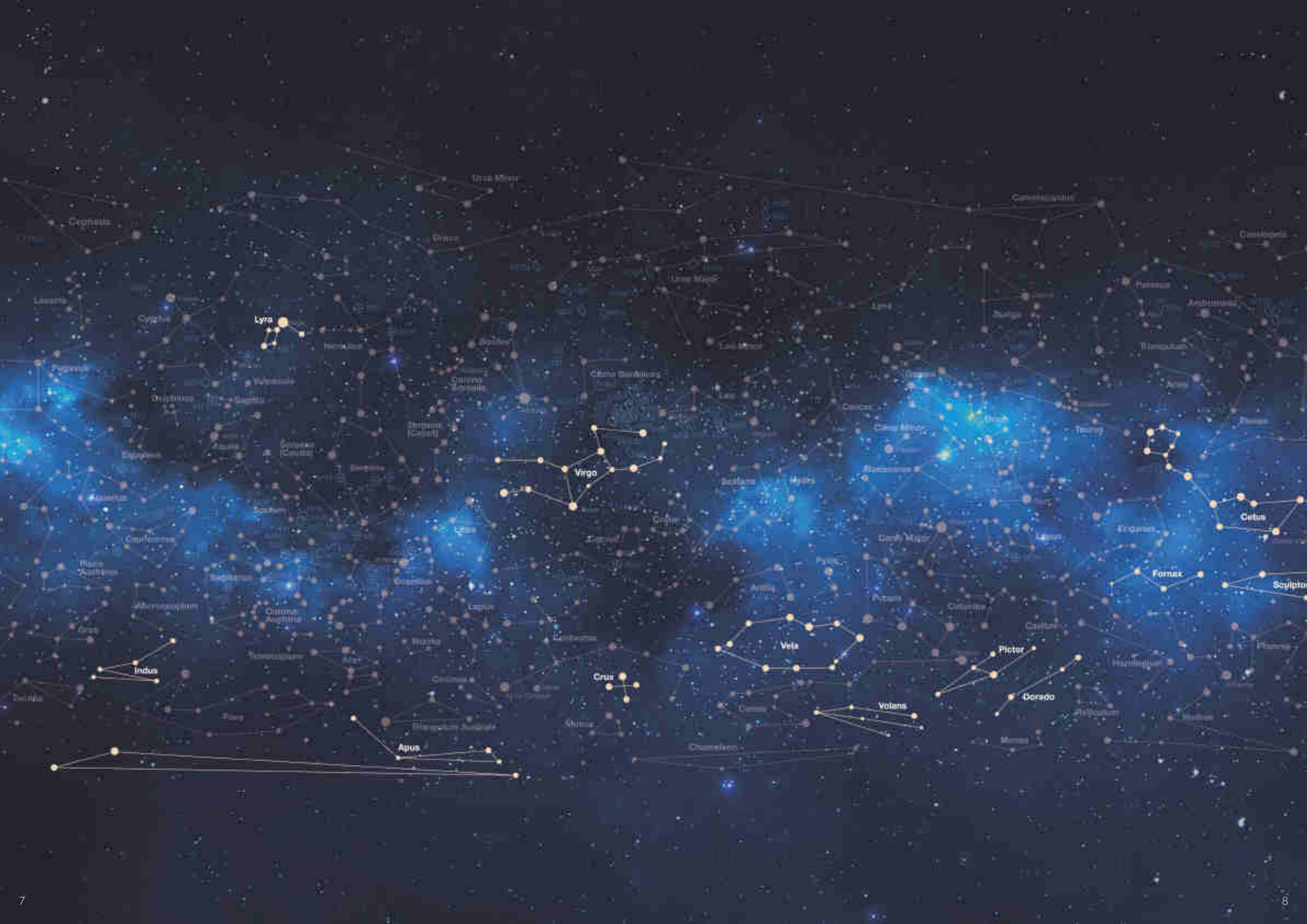

# A MATCH



## TOM CLAEYS - 1965

With Claeys Verlichting, he has been world-renowned for exclusive, timeless designs for thirty years.

“

Sebastiaan used to live right around the corner from me when we were kids. Years later, in 2013, we met up again at a lifestyle show in Knokke-Heist, where I first came across Seba's carbon-fibre chairs. And noticed how every visitor to the stand would pick up one of those featherweight gems with a look of sheer amazement and admiration on their face.

And that was when I realised that my years of searching were finally over: the boy next door I grew up with was the guy I'd been looking for all along. A designer who could create unique chandeliers for my lighting universe. Seba, if you can make chairs like that, then you can also design decorative lighting in carbon fibre...

We brainstormed about light, light values and lighting compositions for hours on end. I outlined what I wanted from Seba and then gave him a completely free hand to think, create and work. He would spend hours in his studio and it was just fascinating to watch him grappling with massive spheres of carbon fibre.

But the end result was a magnificent collection of about thirty hand-made lamps and chandeliers crafted in carbon fibre. That would become our prêt à porter collection.

Then things started moving very quickly. The pieces we selected for the World Expo in Milan in 2015 marked a turning point: we blew away the entire architectural community with our decorative lighting made of carbon fibre. But we knew we could do even better. That guy certainly makes you dream.

Seba's next challenge was to design the world's largest chandelier for a luxury shopping mall in a huge building in Antwerp. Guinness Book of Records: check! On the back of that, we won commissions to design chandeliers for ten carefully selected architectural projects scattered around the globe, ranging from an enormous staircase to an Oriental pavilion. The possibilities seemed endless for us.

And now we're bringing our story to you:  
the biggest, most exclusive, most unique chandelier sculptures in the world.  
Thanks to the combined efforts of two boyhood pals.

”

# MADE IN HEAVEN



## SEBASTIAAN VANDEPUTTE - 1977

Artist, technician and designer "Art-Technician"

“

My first creation was a suspended bath in polyester, followed by a collection of designer furniture in a composite material. **Then I discovered carbon fibre**, and that called for a total rethink: high-tech had to go artisan.

I spent the next two years on a quest, researching and constantly experimenting with various technological processes and different types of carbon fibre. It was pure trial and error.

I travelled all over the globe, from Italy to Japan, looking for the world's top carbon-fibre manufacturers. Getting hold of the quantities I needed as an artist wasn't a problem, but tracking down the specific product I wanted was tougher than I expected. It turned out the kind of carbon fibre I was after was used exclusively in the space industry – and kept firmly under wraps in Europe! But the manufacturer really bought into my dreams and ideas and I managed to import my precious carbon fibre to Belgium, despite the Japanese government's draconian regulations.

The result was a range of furniture, chairs and tables that received international acclaim in the interior design world.

And then a face from the past turned up. Tom had been exhibiting his decorative lighting at the world's most prestigious shows for years and already had many big-name clients. He too was constantly seeking unique beauty and set me a challenge: to create for him the ultimate chandelier in carbon fibre.

So the search was on again, and it would be another long and intensive quest. But my prêt à porter collection was eventually a resounding success. My wall and floor lighting, free-standing lamps and chandeliers took pride of place alongside Tom's prestigious collections in crystal, glass, porcelain and wood.

A match made in heaven. He creates business; I connect ideas in decoration and design...

And I keep dreaming and exploring the boundaries. A chandelier that goes right through glass, 30 by 20 metres in size... The only limit is your own imagination. Try me.

”





## APUS, CETUS, INDUS, VELA...

**Carbon is the raw material that lies at the origin of our lighting universe. No other chemical element forms so many compounds – almost ten million. The best known are diamond, graphite and amorphous carbon. After years of research, Seba was the first person to transform carbon fibre into an artisan product using an industrial process.**

### **PRÊT-À-PORTER - Exclusiveness with soul**

*Our PRÊT-À-PORTER collection creates poetic, atmospheric lighting effects in your home. Our philosophy of embracing traditional values produces a distinctive baroque design language.*

The collection is 'woven' by hand, each item different and unique. Perfect harmony is achieved between the lightweight material and the envisaged silhouette, suggested by a few simple lines. A single fibre has a tensile strength of 1,500 kilograms, which means that the sculptured creations are incredibly strong yet light as a feather.

And the fact that the power supply is virtually invisible makes the whole design even more exclusive.

### **SUR MESURE - Exclusiveness that knows no bounds**

*The SUR MESURE collection is aimed at connoisseurs of design who want to be light years ahead. Our only limit is our imagination. And we're not afraid to give it free rein.*

Our brand of *haute couture* is a wholly unique interpretation of the classic chandelier, free from space limitations and seamlessly blending into the architectural context. Our lighting is designed to fit perfectly into the designated space within a building and is symmetrically and asymmetrically fashioned into one huge, suspended, geometric ensemble.

The effect is out of this world.

Which is why we named our products after constellations as unique as our lighting sculptures.



## KING OF THE ELEMENTS

### TECHNICAL INFO

#### ***An exclusive and sensational material and production process***

Carbon, one of the few chemical elements known since antiquity, is non-metallic, extremely expensive and has a unique diversity of organic compounds, earning it the moniker 'King of the Elements'. The isotope carbon-14 has a half-life of 5,730 years. Carbon fibre is made up of 24,000 fibres (24K) and in pre-cured form can be cut with scissors. It is made by a chemical process called pyrolysis – a well-kept secret that smacks of alchemy – in which, under very high pressure and at a temperature of 3000°C, precursor fibres (e.g. acrylic) are transformed into carbon fibre at almost the molecular level.

The secret artisan production process requires an ambient temperature of 26°C and involves mixing the carbon fibres with epoxy. They are then applied to a mould by hand and left to harden at 60°C for three days.

The carbon-fibre spheres produced can reach a height of 2 metres, making them extremely physically demanding to work with.

The world of haute couture lighting knows virtually no limits. The items created, which are always conceived as a single element, can range in size up to 20 metres.

One finished sphere may contain up to 400 metres of carbon fibre, while there may be as many as 160 spheres in one chandelier.

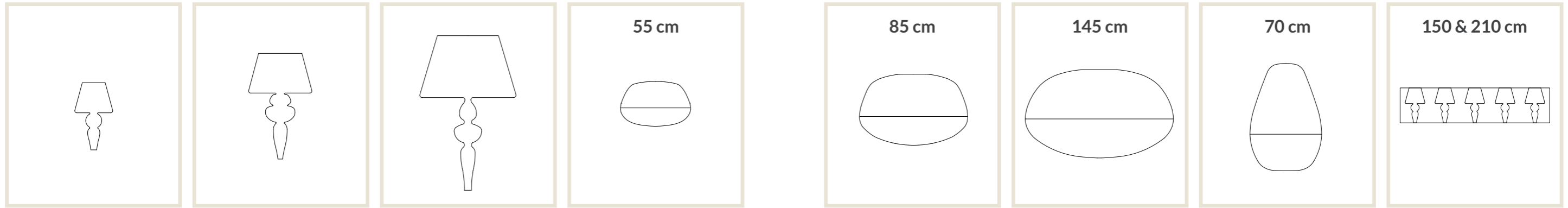

LYRA SMALL

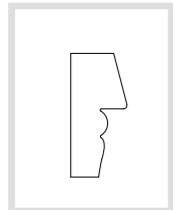

LYRA TABLE

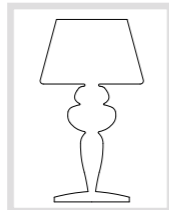

LYRA FLOOR

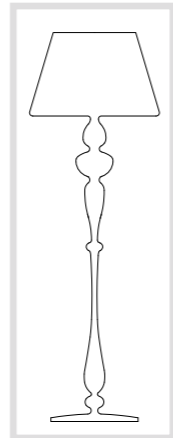

APUS SMALL



APUS MEDIUM

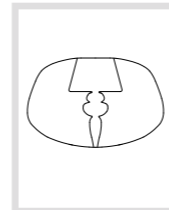

APUS LARGE

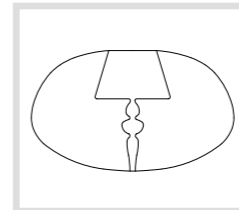

VELA

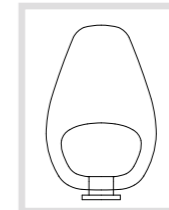

SCULPTOR MEDIUM

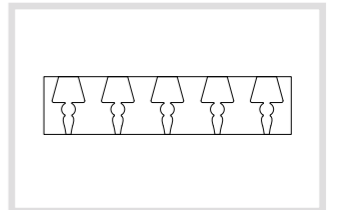

LYRA MEDIUM

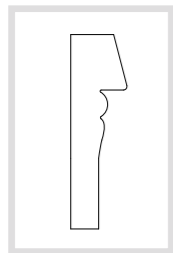

CETUS SMALL

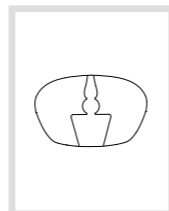

CETUS MEDIUM

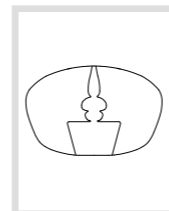

CETUS LARGE

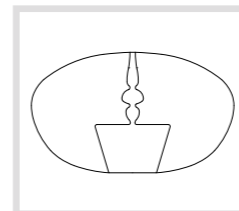

VIRGO

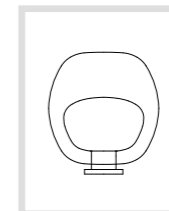

SCULPTOR LARGE

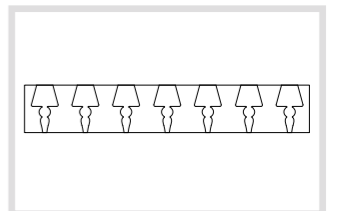

LYRA LARGE

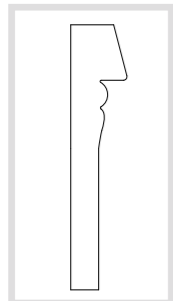

INDUS SMALL

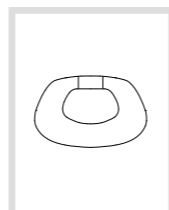

INDUS MEDIUM

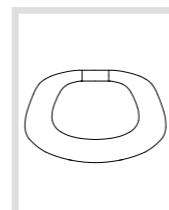

INDUS LARGE

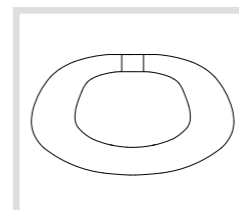

VOLANS

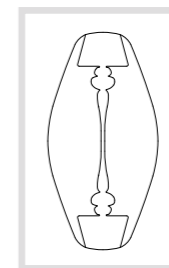

INDUS FLOOR SMALL

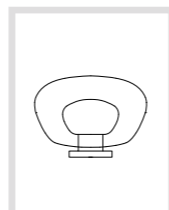

INDUS FLOOR MEDIUM

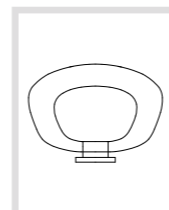

APUS MULTI LARGE

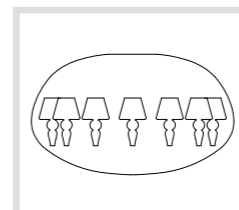

PICTOR

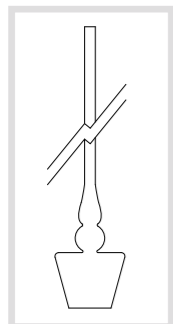

FORNAX SMALL



FORNAX MEDIUM

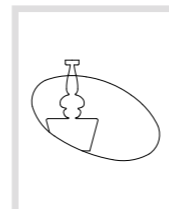

APUS MULTI MEDIUM

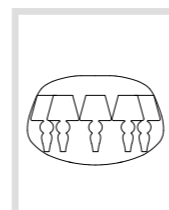





GOLD



COPPER



BRONZE

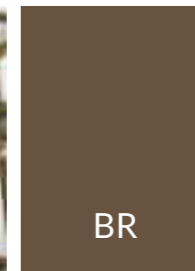

SILVER



WHITE

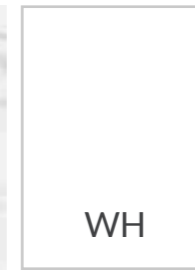

BLACK







# HAUTE COUTURE CARBON

“SUR MESURE”



# HAUTE COUTURE CARBON

## “SUR MESURE”



### **SUR MESURE - Exclusiveness that knows no bounds**

*The SUR MESURE collection is aimed at connoisseurs of design who want to be light years ahead. Our only limit is our imagination. And we're not afraid to give it free rein.*

Our brand of *haute couture* is a wholly unique interpretation of the classic chandelier, free from space limitations and seamlessly blending into the architectural context. Our lighting is designed to fit perfectly into the designated space within a building and is symmetrically and asymmetrically fashioned into one huge, suspended, geometric ensemble.

The effect is out of this world.

Which is why we named our products after constellations as unique as our lighting sculptures.



**'FOR ROYALTY...'**

Queen Mathilde of Belgium discovers Tom and Seba's universe at the World Expo 2015 in Milan and is won over immediately.



MILANO 2015  
FEEDING THE PLANET  
ENERGY FOR LIFE



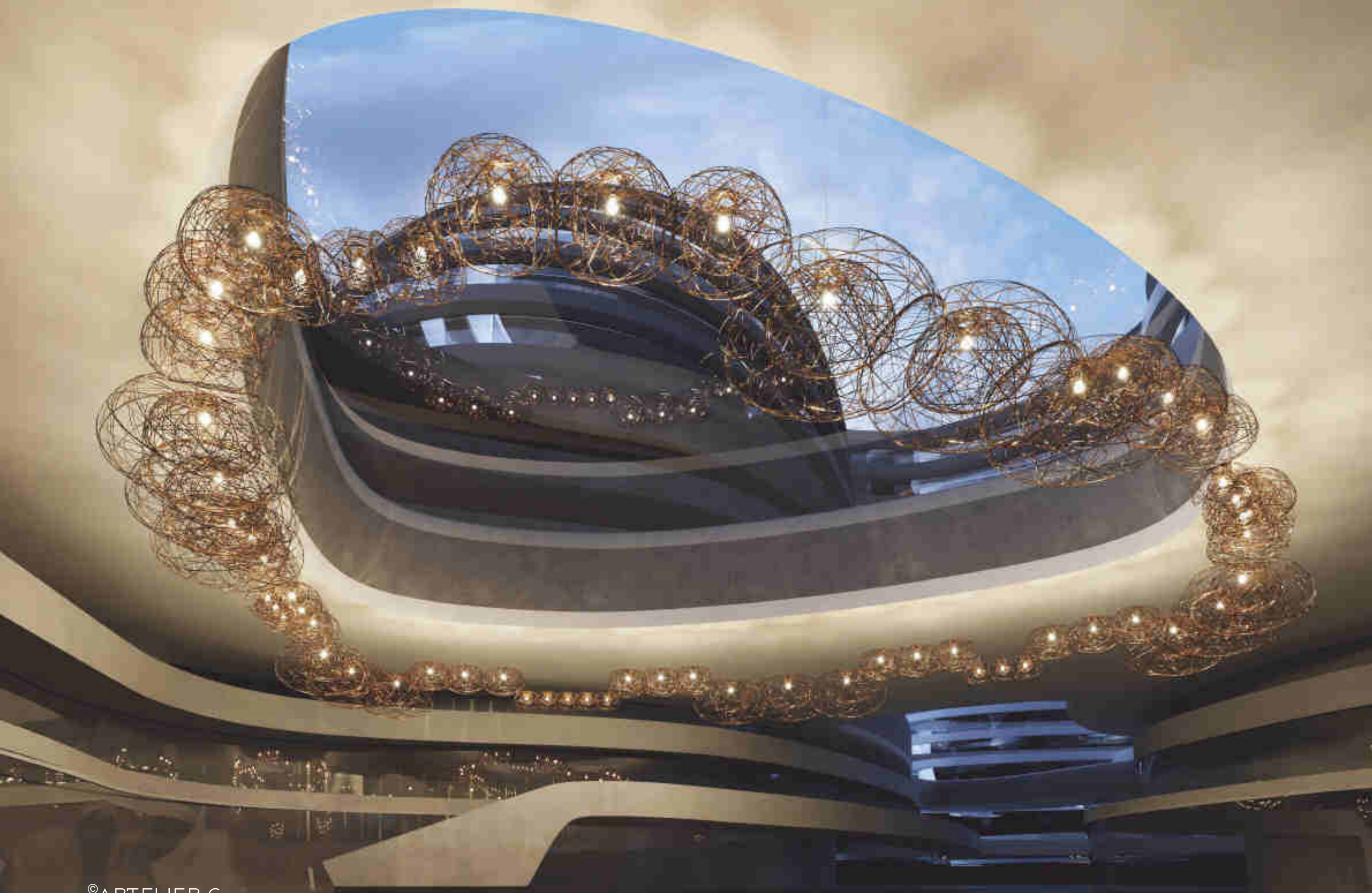

©ARTELIER C  
HAUTE COUTURE LIGHT ORNAMENTS

INDUS shoppingmall  
L32m - D24m - H1,3m - 45 kg





©ARTELIER C  
HAUTE COUTURE LIGHT ORNAMENTS

INDUS living room  
L6,8m - D3,4m - H4,4m - 8,5 kg







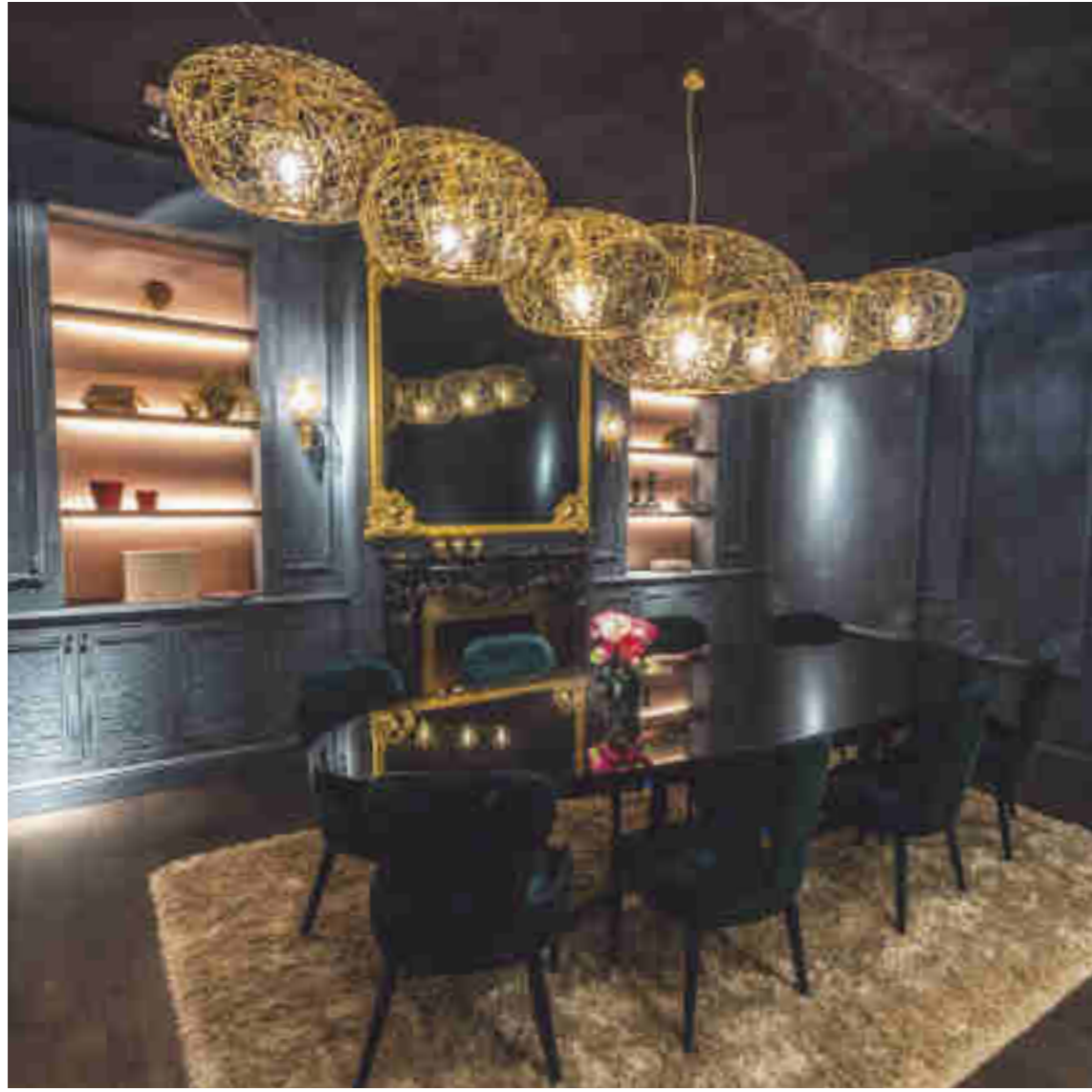

©ARTELIER C  
HAUTE COUTURE LIGHT ORNAMENTS

< CETUS dining room - > APUS entrance





©ARTELIER C  
HAUTE COUTURE LIGHT ORNAMENTS

APUS cathedral  
Ø18m - H18m - 125 kg





©ARTELIER C  
HAUTE COUTURE LIGHT ORNAMENTS  
PICTOR staircase







©ARTELIER C  
HAUTE COUTURE LIGHT ORNAMENTS

INDUS icehotel  
L6m - D3,6m - H3,6m - 10 kg













©ARTELIER C  
HAUTE COUTURE LIGHT ORNAMENTS

VOLANS staircase  
Ø5,5m - H4,4m - 92 kg





©ARTELIER C  
HAUTE COUTURE LIGHT ORNAMENTS

APUS meeting room  
L4,8m - D1m - H1m - 5,65 kg







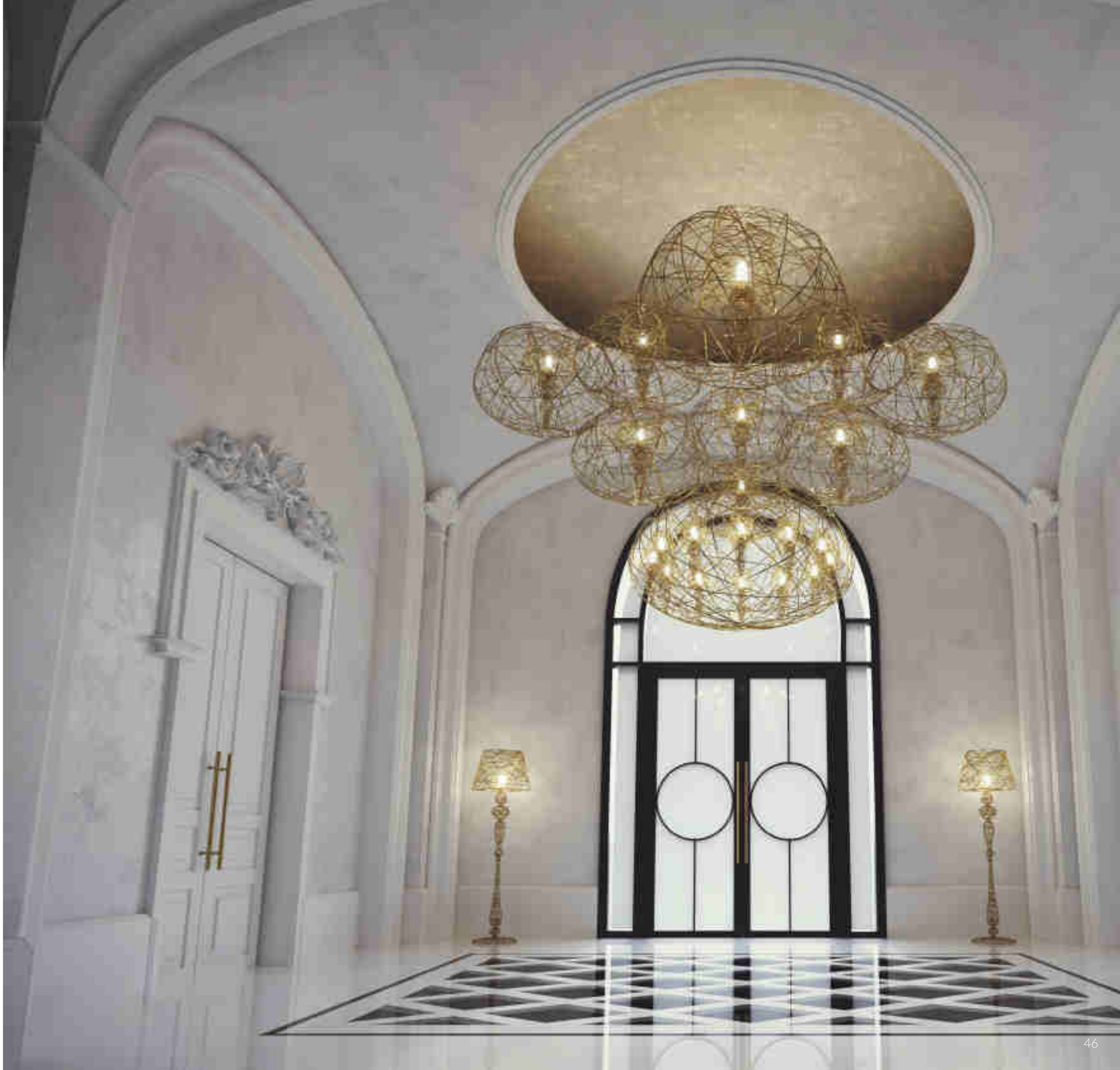

©ARTELIER C  
HAUTE COUTURE LIGHT ORNAMENTS

APUS entrance hall  
Ø3,8m - H2,6m - 9,25 kg





©ARTELIER C  
HAUTE COUTURE LIGHT ORNAMENTS

INDUS living room - wall  
L4m - D1m - H3,6m - 7,3 kg





©ARTELIER C  
HAUTE COUTURE LIGHT ORNAMENTS  
APUS kitchen







©ARTELIER C  
HAUTE COUTURE LIGHT ORNAMENTS

APUS hotel lobby  
Ø14m - H0,85m - 23 kg



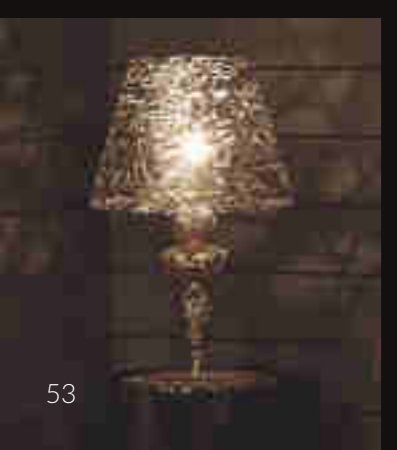

# HAUTE COUTURE CARBON

“PRÊT-À-PORTER”





# HAUTE COUTURE CARBON

## “PRÊT-À-PORTER”

### PRÊT-À-PORTER - Exclusiveness with soul

*Our PRÊT-À-PORTER collection creates poetic, atmospheric lighting effects in your home. Our philosophy of embracing traditional values produces a distinctive baroque design language.*

The collection is 'woven' by hand, each item different and unique. Perfect harmony is achieved between the lightweight material and the envisaged silhouette, suggested by a few simple lines. A single fibre has a tensile strength of 1,500 kilograms, which means that the sculptured creations are incredibly strong yet light as a feather.

And the fact that the power supply is virtually invisible makes the whole design even more exclusive.

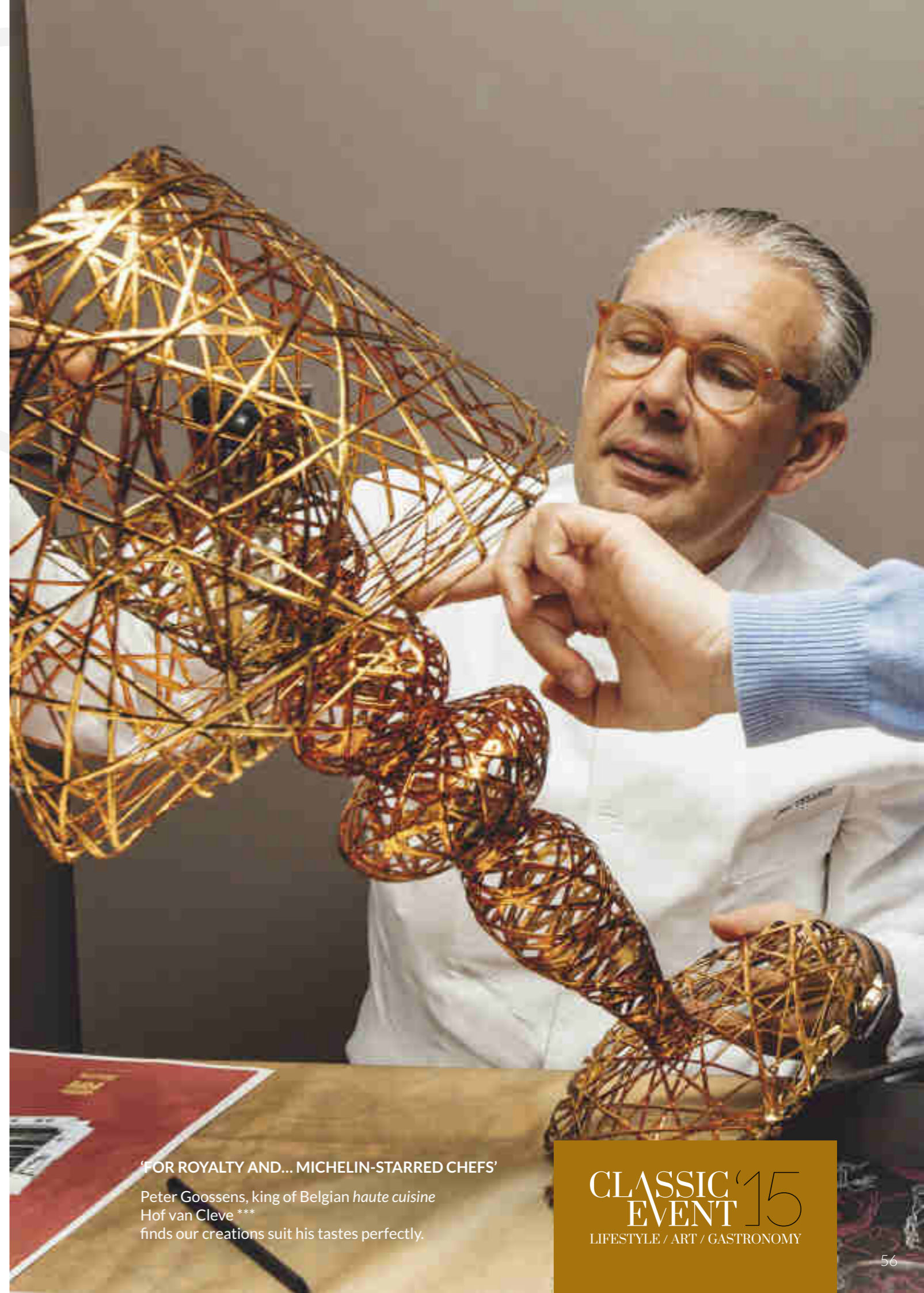

**‘FOR ROYALTY AND... MICHELIN-STARRED CHEFS’**

Peter Goossens, king of Belgian *haute cuisine*  
Hof van Cleve \*\*\*  
finds our creations suit his tastes perfectly.

**CLASSIC** '15  
**EVENT**  
LIFESTYLE / ART / GASTRONOMY





# CEILING SUSPENDED

APUS	59
CETUS	61
INDUS	63
APUS MULTI	65
SCULPTOR	67
COMBINATION 1	69
COMBINATION 2	71
COMBINATION 3	73
VOLANS COMBINATION	75
DORADO COMBINATION	77





SMALL

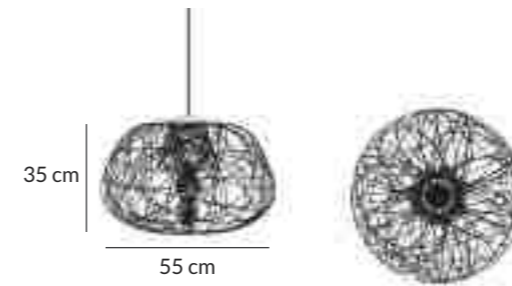

MEDIUM

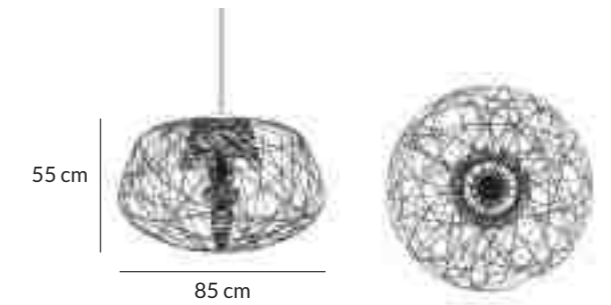

LARGE

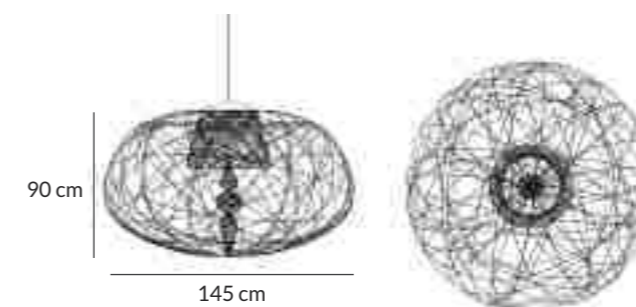

CEILING SUSPENDED APUS					
SMALL	MEDIUM	LARGE			
APCS55.Ø	APCS85.Ø	APCS145.Ø			
Ø55cm*H35cm	Ø85cm*H55cm	Ø145cm*H90cm			
0,35 kg	0,55 kg	1,40 kg			
E14	E27	E27			
Led Candle Clear	Led Bulb Clear	Led Bulb Clear			
Cable suspension length: 3 m incl.					
Cable 3 x 0,75 mm <sup>2</sup>					
120-240v/50-60hz					
ip20					
Ø	CU	BR	SI	WH	BL



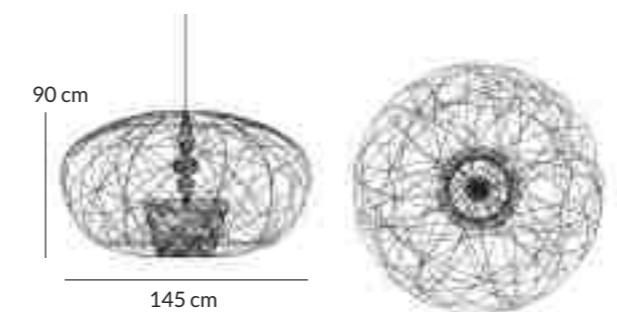
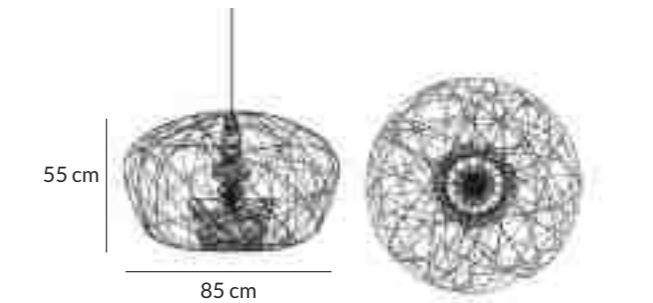
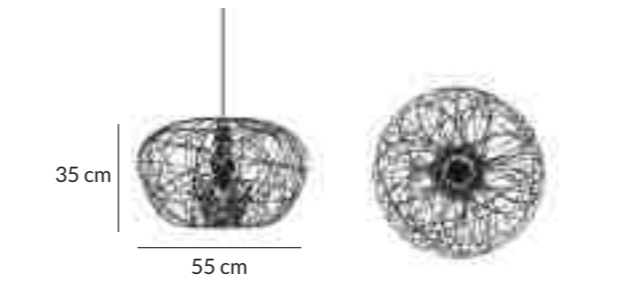

CEILING SUSPENDED CETUS					
SMALL	MEDIUM	LARGE			
CECS55.∅	CECS85.∅	CECS145.∅			
∅55cm*H35cm	∅85cm*H55cm	∅145cm*H90cm			
0,35 kg	0,55 kg	1,40 kg			
E14	E27	E27			
Led Candle Clear	Led Bulb Clear	Led Bulb Clear			
Cable suspension length: 3 m incl.					
Cable 3 x 0,75 mm <sup>2</sup>					
120-240v/50-60hz					
ip20					
∅	CU	BR	SI	WH	BL





SMALL

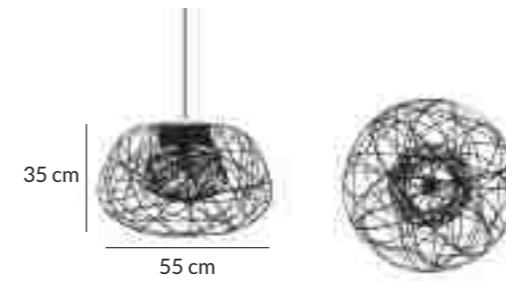

MEDIUM

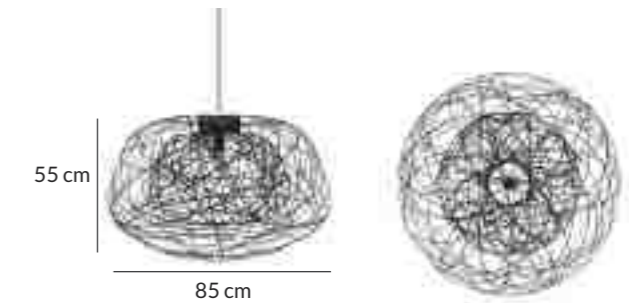

LARGE

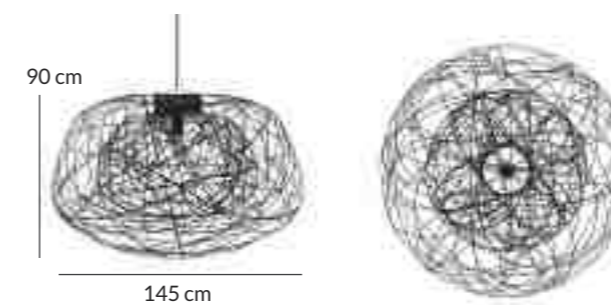

CEILING SUSPENDED INDUS					
SMALL	MEDIUM	LARGE			
INCS55.∅	INCS85.∅	INCS145.∅			
∅55cm*H35cm	∅85cm*H55cm	∅145cm*H90cm			
0,35 kg	0,55 kg	1,40 kg			
E27	E27	E27			
Led Bulb Clear	Led Bulb Clear	Led Bulb Clear			
Cable suspension length: 3 m incl.					
Cable 3 x 0,75 mm <sup>2</sup>					
120-240v/50-60hz					
ip20					
∅	CU	BR	SI	WH	BL



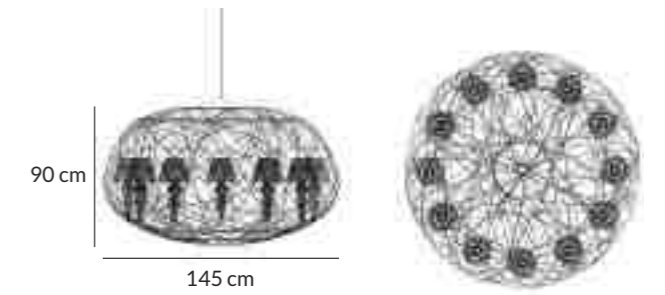
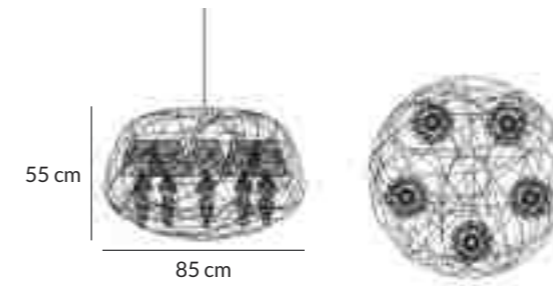

CEILING SUSPENDED APUS MULTI					
APUS MULTI MEDIUM			APUS MULTI LARGE		
APMCS85.∅			APMCS145.∅		
Ø85cm*H55cm			Ø145cm*H90cm		
1,40 kg			2,90 kg		
5 * E14			12 * E14		
Led Candle Clear			Led Candle Clear		
Cable suspension length: 3 m incl.					
Cable 3 x 0,75 mm <sup>2</sup>					
120-240v/50-60hz					
ip20					
∅	CU	BR	SI	WH	BL
GO	CU	BR	SI	WH	BL



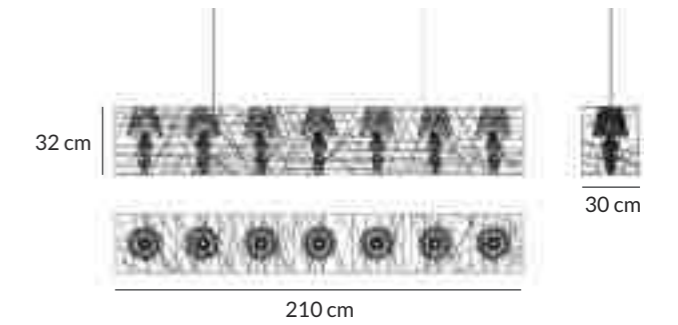
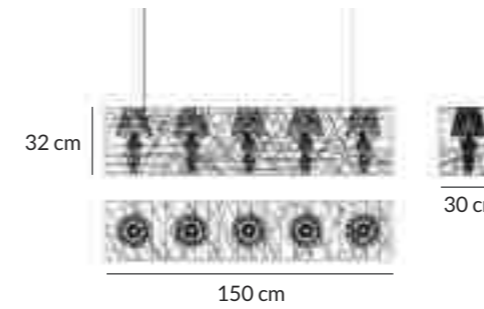

CEILING SUSPENDED SCULPTOR						
SMALL			MEDIUM			
SCCS150.∅			SCCS210.∅			
L150cm*D30cm*H32cm			L210cm*D30cm*H32cm			
1,40 kg			1,95 kg			
5 * E14			7 * E14			
Led Candle Clear			Led Candle Clear			
Cable suspension length: 3 m incl.						
Cable 3 x 0,75 mm <sup>2</sup>						
120-240v/50-60hz						
ip20						
∅	GO	CU	BR	SI	WH	BL



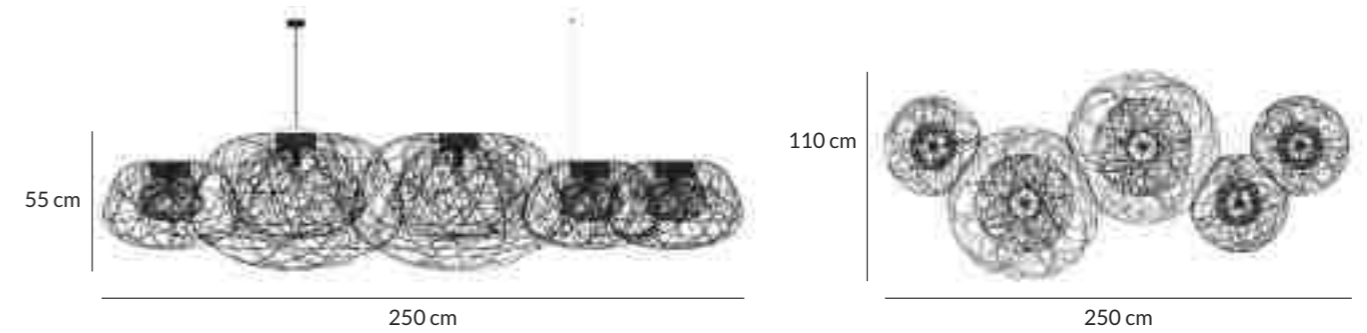



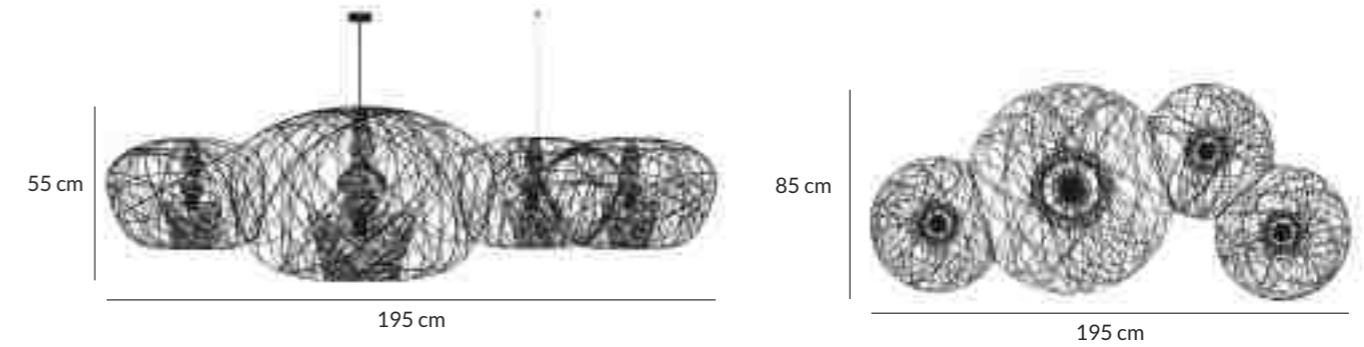

CEILING SUSPENDED COMBINATION 1 - AVAILABLE IN APUS, CETUS AND INDUS

APUS COMBINATION 1		CETUS COMBINATION 1		INDUS COMBINATION 1		
APCSCO1.250.∅		CECSCO1.250.∅		INCSCO1.250.∅		
L250cm*H55cm*D110cm		L250cm*H55cm*D110cm		L250cm*H55cm*D110cm		
3,30 kg		3,30 kg		3,30 kg		
3 * Small Ø55*H35	2 * Medium Ø85*H55	3 * Small Ø55*H35	2 * Medium Ø85*H55	3 * Small Ø55*H35	2 * Medium Ø85*H55	
E14 Led Bulb Clear	E27 Led Bulb Clear	E14 Led Bulb Clear	E27 Led Bulb Clear	E27 Led Bulb Clear	E27 Led Bulb Clear	
Cable suspension length: 3 m incl.						
Cable 3 x 0,75 mm <sup>2</sup>						
120-240v/50-60hz						
ip20						
∅	GO	CU	BR	SI	WH	BL











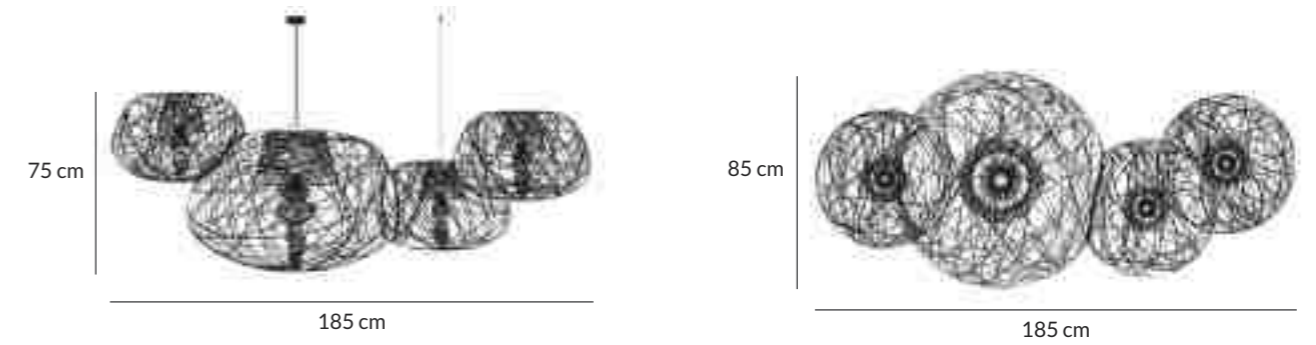

CEILING SUSPENDED COMBINATION 2 - AVAILABLE IN APUS, CETUS AND INDUS

APUS COMBINATION 2		CETUS COMBINATION 2		INDUS COMBINATION 2		
						
APCSCO2.185.∅		CECSCO2.185.∅		INDCSCO2.185.∅		
L195cm*H55cm*D85cm		L195cm*H55cm*D85cm		L195cm*H55cm*D85cm		
2,25 kg		2,25 kg		2,25 kg		
3 * Small Ø55*H35	1 * Medium Ø85*H55	3 * Small Ø55*H35	1 * Medium Ø85*H55	3 * Small Ø55*H35	1 * Medium Ø85*H55	
E14 Led Bulb Clear	E27 Led Bulb Clear	E14 Led Bulb Clear	E27 Led Bulb Clear	E27 Led Bulb Clear	E27 Led Bulb Clear	
Cable suspension length: 3 m incl.						
Cable 3 x 0,75 mm <sup>2</sup>						
120-240v/50-60hz						
ip20						
∅	GO	CU	BR	SI	WH	BL



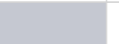

CEILING SUSPENDED APUS COMBINATION 3 - AVAILABLE IN APUS, CETUS AND INDUS						
						
<b>APUS COMBINATION 3</b>		<b>CETUS COMBINATION 3</b>		<b>INDUS COMBINATION 3</b>		
APCSCO3.185.∅		CECSCO3.185.∅		INCSCO3.185.∅		
L185cm*H75cm*D85cm		L185cm*H75cm*D85cm		L185cm*H75cm*D85cm		
2,25 kg		2,25 kg		2,25 kg		
3 * Small Ø55*H35	1 * Medium Ø85*H55	3 * Small Ø55*H35	1 * Medium Ø85*H55	3 * Small Ø55*H35	1 * Medium Ø85*H55	
E14 Led Bulb Clear	E27 Led Bulb Clear	E14 Led Bulb Clear	E27 Led Bulb Clear	E27 Led Bulb Clear	E27 Led Bulb Clear	
Cable suspension length: 3 m incl.						
Cable 3 x 0,75 mm <sup>2</sup>						
120-240v/50-60hz						
ip20						
∅	GO	CU	BR	SI	WH	BL
						



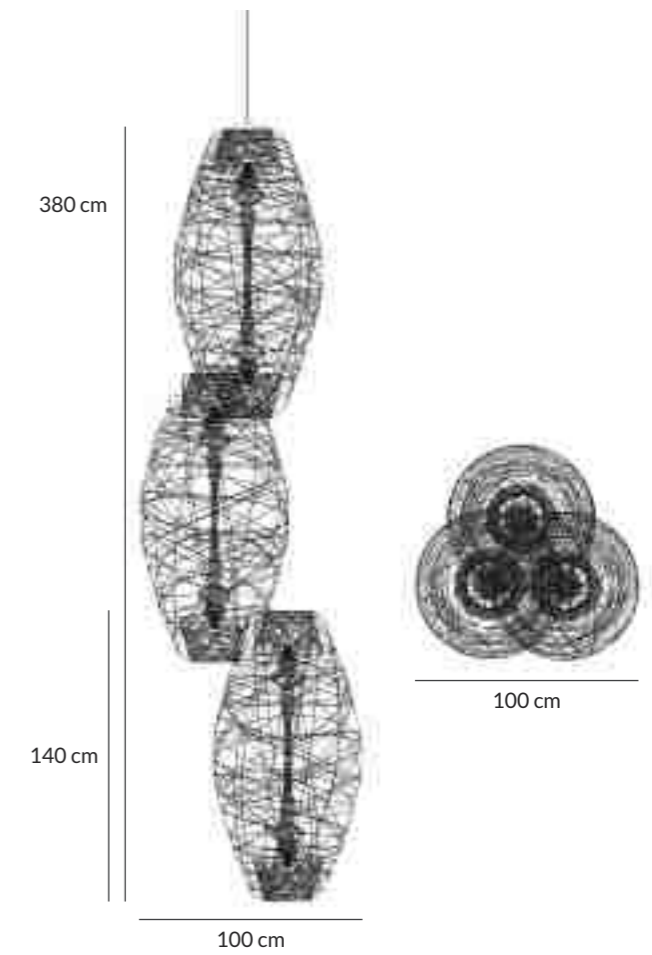



CEILING SUSPENDED VOLANS					
VOCS100.◇					
Ø100cm*H380cm					
3,30 kg					
6 * E27 Led Bulb Clear					
Cable suspension length: 3 m incl.					
Cable 3 x 0,75 mm <sup>2</sup>					
120-240v/50-60hz					
ip20					
◇					
GO	CU	BR	SI	WH	BL

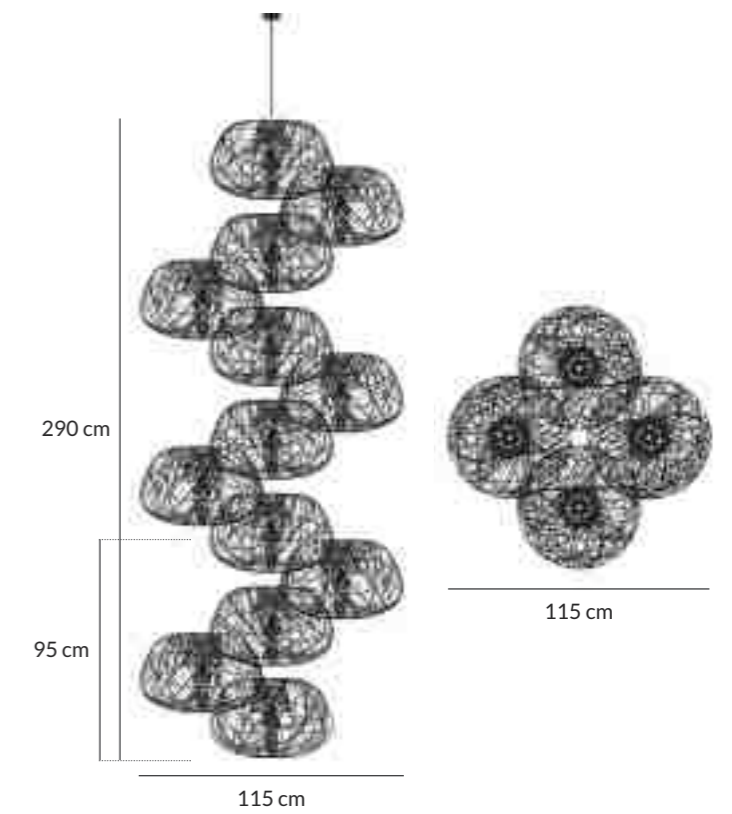



CEILING SUSPENDED DORADO COMBINATION - AVAILABLE IN APUS, CETUS AND INDUS							
							
<b>DORADO 1 APUS</b>	<b>DORADO 2 CETUS</b>	<b>DORADO 3 INDUS</b>					
DOCSAP55.Ø	DOCSCE55.Ø	DOCSIND55.Ø					
Ø115cm*H290cm	Ø115cm*H290cm	Ø115cm*H290cm					
4,55 kg	4,55 kg	4,80 kg					
13 * Small Ø55*H35	13 * Small Ø55*H35	13 * Small Ø55*H35					
E14 Led Candle Clear	E14 Led Candle Clear	E27 Led Bulb Clear					
Cable suspension length: 3 m incl.							
Cable 3 x 0,75 mm <sup>2</sup>							
120-240v/50-60hz							
ip20							
Ø	GO	CU	BR	SI	WH	BL	





---

# CEILING DIRECT

---

FORNAX 81

INDUS 83

---



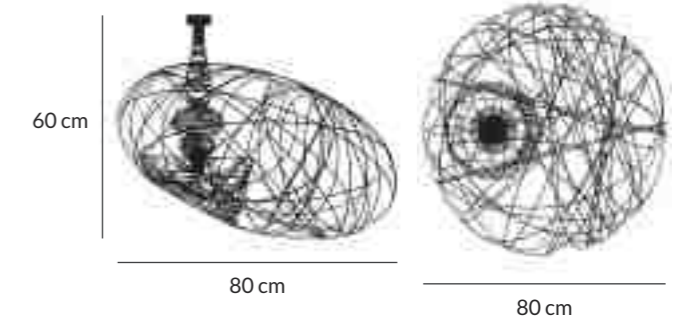
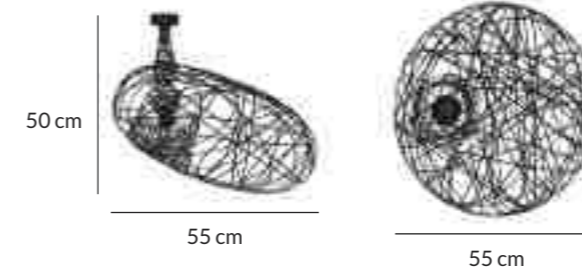

CEILING DIRECT FORNAX					
SMALL			MEDIUM		
FOCD50.◇			FOCD80.◇		
Ø55cm*H50cm			Ø80cm*H60cm		
0,35 kg			0,55 kg		
E14 Led Bulb Clear			E27 Led Bulb Clear		
Cable 3 x 0,75 mm <sup>2</sup>					
120-240v/50-60hz					
ip20					
.XGO	CU	BR	SI	WH	BL





SMALL

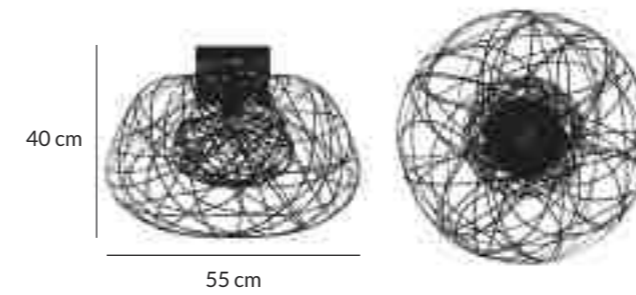

CEILING DIRECT INDUS						
SMALL						
INCD55.Ø						
Ø55cm*H40cm						
0,37 kg						
E27 Led Bulb Clear						
Cable 3 x 0,75 mm <sup>2</sup>						
120-240v/50-60hz						
ip20						
∅	GO	CU	BR	SI	WH	BL





---

# WALL

---

LYRA

87

---



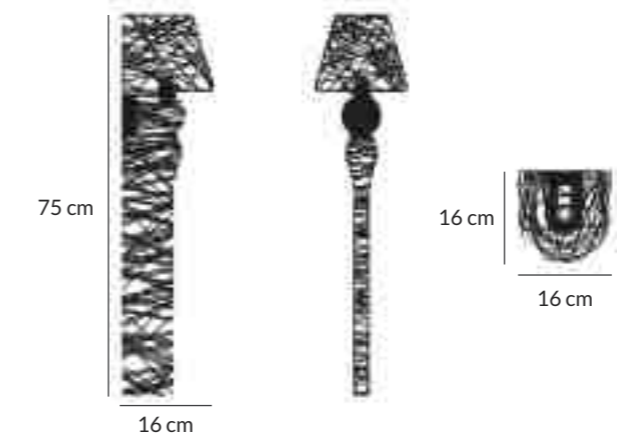
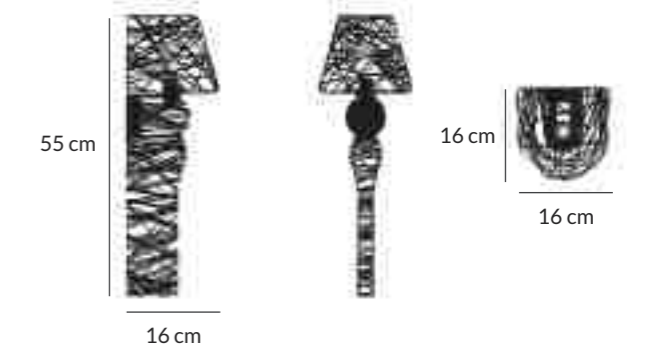

WALL LYRA					
SMALL	MEDIUM	LARGE			
LYWL35.∅	LYWL55.∅	LYWL75.∅			
L16cm*D16cm*H35cm	L16cm*D16cm*H55cm	L16cm*D16cm*H75cm			
0,19 kg	0,20 kg	0,21 kg			
E14	E14	E14			
Led Candle Clear	Led Candle Clear	Led Candle Clear			
Cable 3 x 0,75 mm <sup>2</sup>					
120-240v/50-60hz					
ip20					
∅	CU	BR	SI	WH	BL
GO	CU	BR	SI	WH	BL









---

# FLOOR FREE STANDING

---

LYRA FLOOR 93

INDUS FLOOR 95

VIRGO 97

VELA 99

CRUX 101



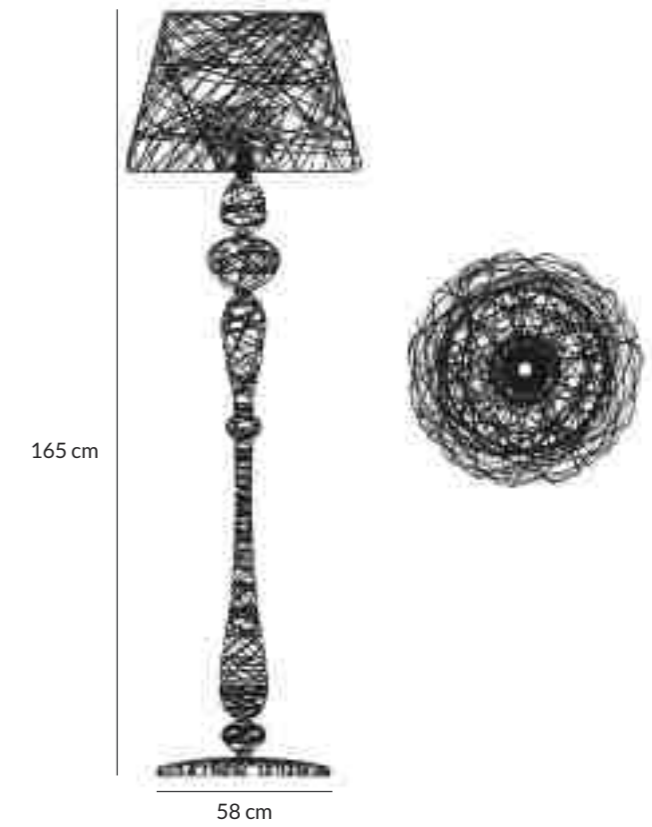

FLOOR FREE STANDING LYRA FLOOR					
LYFR165.Ø					
Ø58cm*H165cm					
1,20 kg					
E27 Led Bulb Clear					
Cable length: on demand					
Cable 3 x 0,75 mm <sup>2</sup>					
120-240v/50-60hz					
ip20					
Ø	CU	BR	SI	WH	BL
GO					





SMALL



MEDIUM

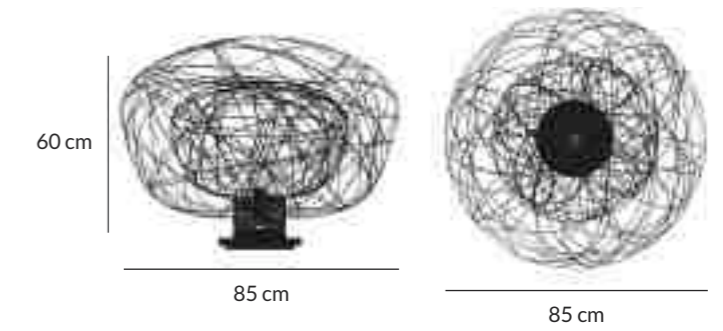
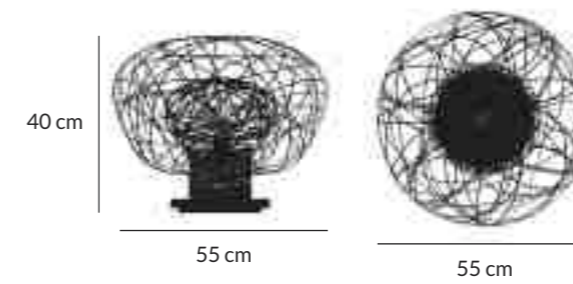

FLOOR FREE STANDING INDUS FLOOR					
SMALL			MEDIUM		
INFR55.∅			INFR85.∅		
∅55cm*H40cm			∅85cm*H60cm		
2,30 kg			2,80 kg		
E27 Led Bulb Clear			E27 Led Bulb Clear		
Cable length: on demand					
Cable 3 x 0,75 mm <sup>2</sup>					
120-240v/50-60hz					
ip20					
∅	CU	BR	SI	WH	BL
GO					



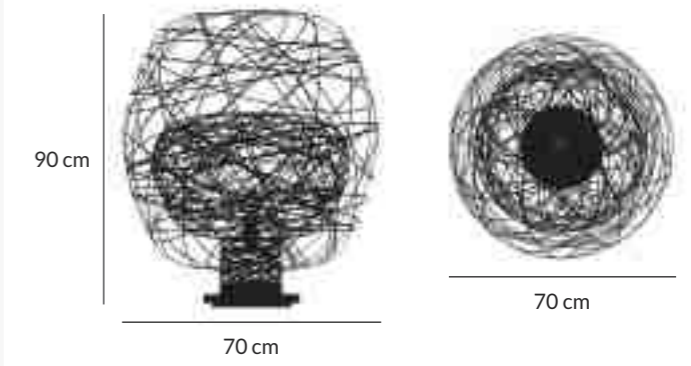

FLOOR FREE STANDING VIRGO					
VIFR85.∅					
∅70cm*H90cm					
2,90 kg					
E27 Led Bulb Clear					
Cable length: on demand					
Cable 3 x 0,75 mm <sup>2</sup>					
120-240v/50-60hz					
ip20					
∅	CU	BR	SI	WH	BL
GO					



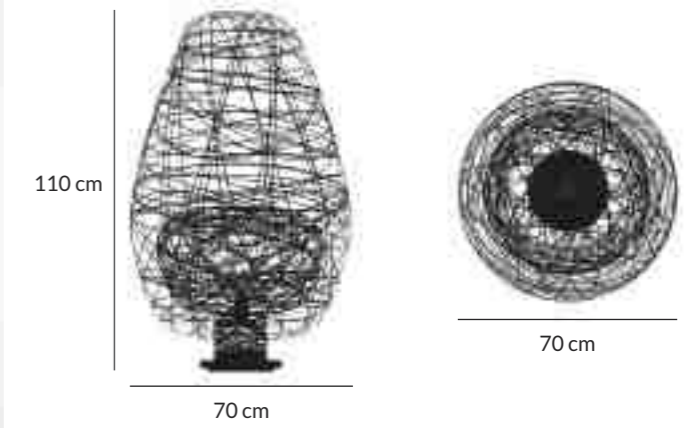

FLOOR FREE STANDING VELA					
VEFR110.◇					
Ø70cm*H110cm					
2,90 kg					
E27 Led Bulb Clear					
Cable length: on demand					
Cable 3 x 0,75 mm <sup>2</sup>					
120-240v/50-60hz					
ip20					
◇					
GO	CU	BR	SI	WH	BL



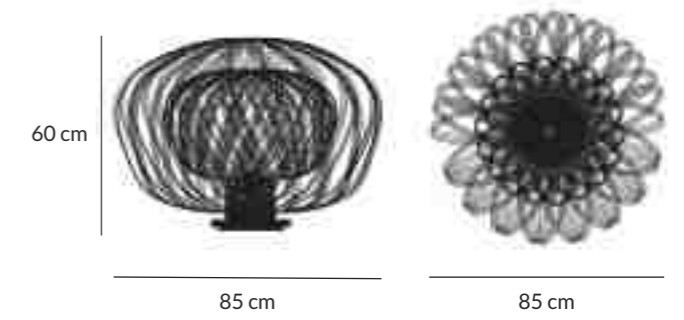

FLOOR FREE STANDING CRUX					
CXFR85.∅					
∅85cm*H60cm					
2,80 kg					
E27 Led Bulb Clear					
Cable length: on demand					
Cable 3 x 0,75 mm <sup>2</sup>					
120-240v/50-60hz					
ip20					
∅	CU	BR	SI	WH	BL
GO					



EXCLUSIVENESS  
WITH  
SOUL







---

# TABLE FREE STANDING

---

LYRA TABLE

107

---



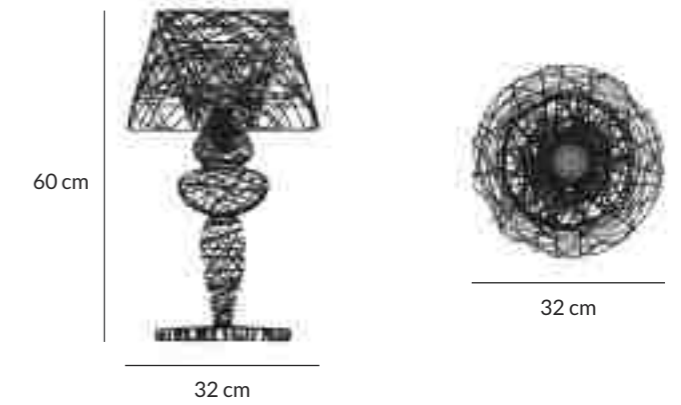

TABLE FREE STANDING LYRA TABLE					
LYTL60.Ø					
Ø32cm*H60cm					
0,40 kg					
E27 Led Bulb Clear					
Cable length: on demand					
Cable 3 x 0,75 mm <sup>2</sup>					
120-240v/50-60hz					
ip20					
Ø	CU	BR	SI	WH	BL





Antarctic Peninsula  
 Base Port Lockroy (Goudier Island)  
 64° 49,6' S  
 063° 30,3' W



MINIATURE LYRA TABLE  
 Antarctic Peninsula  
 Base Port Lockroy (Goudier Island)  
 64° 49,6' S - 063° 30,3' W  
 Ø16cm\*H35cm





STARS CAN'T SHINE  
WITHOUT  
DARKNESS



# ARTELIER C

HAUTE COUTURE LIGHT ORNAMENTS

Product design - research & development - manufacturer: Sebastiaan Vandeputte  
Coordination - concept: Artelier C\* and SAS' nv  
Graphic Design - Production: Artelier C\* and SAS' nv  
Photography: Lenzer - Charly Duke - Luc Coppens

Copyright: Artelier C\* - a brand name of Claeys Verlichting bvba  
December 2017 - first edition

Made in Belgium

Please visit our website at [www.artelierc.com](http://www.artelierc.com) for the latest information.

All information in this catalogue is provided for information purposes only and Artelier C\* makes no representations about its accuracy or completeness.

Artelier C\* reserves the right to change the information and technical data in this catalogue without notice. The catalogue does not constitute any guarantee regarding Artelier C\* products or any implied warranty of fitness for a particular purpose.

All Artelier C\* products are supplied without lamps and lamp data is given as an example.

The general terms and conditions of Claeys Verlichting bvba shall be applicable to all sales of Artelier C\* products. All trademarks, text, images, graphics, designs and other information in this catalogue are the sole property and subject to the intellectual property rights of Claeys Verlichting bvba, and may not be copied, modified or used for any purpose without prior written consent.

\*: a brand name of Claeys Verlichting bvba

ARTELIER C  
Doorniksesteenweg 237 - 8580 Avelgem - Belgium - T +32 56 64 48 40 - M +32 495 30 48 40  
[info@artelierc.com](mailto:info@artelierc.com) - [www.artelierc.com](http://www.artelierc.com)

HAUTE COUTURE  
CARBON  
BY SEBASTIAAN VANDEPUTTE  
FOR  
ARTELIER C  
HAUTE COUTURE LIGHT ORNAMENTS

